

# Markland New Member Packet

---

Wes Tu Ha! First of all, many thanks to Patricia Martel aka Dame Katherine Theodosia von Katzenelnbogen for putting together the original informational package back in the early 2000s. With her blessing, I have attempted to update this to reflect Markland information as it stands today.

This information packet for newcomers is designed to provide you with slightly more than basic information that will start you out well in your Markland experience and is a continual work in progress. Feel free to contact me with corrections, additions, and other suggestions at: lisenm023@gmail.com.

Yours in service,  
Lisen Minetti aka Liana Cantomir, House Rivenwood

## Table of Contents:

A Brief History of Markland .....	1
Mission of Markland .....	2
What Membership Entitles You to Have .....	2
❖ The Pox .....	2
❖ The Plague .....	2
o Plague & Pox Submissions .....	2
❖ Insurance .....	2
❖ Voting .....	2
Intro to Hierarchy.....	3
❖ Witan.....	3
o Aeldorman — The President.....	3
o Shire-reeve — The Vice President.....	3
o Bocman — The Secretary.....	3
o Bailiff — The Treasurer.....	3
o Plague/Pox Editor.....	3
o Fyrd or Folk.....	3
Types of Events.....	3
❖ Althyngs .....	3
❖ Council Meetings.....	3
❖ Wars and Frat Events.....	3
❖ Feasts.....	3

❖ Arts and Sciences(A&S).....	3
❖ Fighter Practices.....	3
❖ Historical Encampments/Living History.....	3
❖ Rec Events.....	3

Markland Code Words.....	4
❖ Beverages.....	4
❖ Flame.....	4
❖ Garb.....	4
❖ Event Ratings.....	4
❖ Markland Fighting.....	4
o Frat.....	4
o Recreational or Steel.....	4
o Period Fencing.....	4

Markland Households/Guilds.....	5
Garb.....	5

Garb Patterns.....	6
--------------------	---

Camping & Feast Gear.....	7
---------------------------	---

List of Individual Specialties.....	8
-------------------------------------	---

---

## A Brief History of Markland

Members of the University of Maryland Fencing Club first conceived Markland in 1969. They were influenced by a number of factors: Olivier's Henry V, The Vikings starring Kirk Douglas, The Last Englishman by Weenelson and a description of The Battle of Hastings in a recent National Geographic. Atli suddenly had the wonderful idea: "Hey, you know, we should re-enact Hastings!" The inevitable response came: "What a great idea!"

The first re-enactment of the Battle of Hastings took place outside the North West Branch Library in Anacostia, Maryland. The mini battles took place beside the McKeldin Library, the main library on campus at that time. Using Italian bayonets, swords, axes and shields, the participants began beating on stuff and each other. The first battles were six versus five. Despite humble beginnings, a winter battle, Maldon, was scheduled, and as a result clothing improved. Thus we began groping towards historical re-enactment.

## Mission of Markland

Markland Medieval Mercenary Militia, Limited (or, more simply, Markland) is a non-profit educational society dedicated to the study and recreation of the Middle Ages. It was founded in 1969 at the University of Maryland when the first annual re-enactment of the Battle of Hastings was held. Since that time, Markland has re-enacted battles, held frat wars and feasts, performed public demonstrations, educated itself and the public about the Middle Ages, and generally had a lot of fun.

The primary purpose of Markland is deliberately unspecified. In this way we can do all manner of interesting activities: participate in parades, hold feasts, explore medieval crafts, study ancient lifestyles, exchange opinions, hit each other with swords, publish historical research, and so many other things. Markland is a hobby. It can be whatever we make of it.

What you need to get started is membership, garb, and gear.

### What Membership Entitles You to Have:

- ❖ Voting privileges at the Summer and Winter Althyngs
- ❖ Coverage under our group liability insurance
- ❖ The option of additional Fighter's Insurance
- ❖ The ability to fight at Crown War
- ❖ A subscription to *The Plague* and *The Pox* and reduced advertising rates in *The Plague*
- ❖ Access to member-only sections of [www.markland.org](http://www.markland.org)

*The Pox* is the newsletter containing Events Schedule and Contact Listings.

*The Plague* is a bi-annual newsletter containing information expanding upon *The Pox*. A wonderful resource, it contains the minutes of business meetings in addition to larger articles and columns. Members new and old produce the art and articles in the *Pox* and *Plague*.

### Plague & Pox Submissions

Opinions expressed in this publication are solely those of the contributing authors and do not necessarily represent those of the editor, staff, or Markland. The *Plague/Pox* is published for communication to all Markland members and as an official corporate record. A policy of fair accesses and niceness of demeanor will be upheld by the Editor, staff, and members of the Witan. The *Plague/Pox* Staff determines if and when a submission is published.

## Please send all Pox/Plague submissions to:

Lisen Minetti  
Persona: Liana Cantomir

Megan Gallagher  
Persona: Brenna Brynwyf

Markland.Plague@gmail.com

---

### Insurance

Markland has two kinds of insurance, general liability and fighter's insurance. Your group leader is responsible for making sure that you understand the rules of Markland. This includes how our insurance works. General liability applies only to official Markland events and covers and damages to persons or property not belonging to Markland if said damage was done by a Marklander. Only members are covered. If you bring the local village idiot who decides to start fire-jumping and sets the woods on fire, Markland is not responsible or liable financially for those damages.

### Fighter's Insurance

Fighter's insurance is a supplementary insurance provided for a nominal fee to members of Markland to cover them at official Markland events. It is not limited strictly to fighters or to injuries that occur on the frat field. However it is strictly limited to members and official events.

If you currently have health insurance (independent of Markland) then you will not have any real need for fighter's insurance as you would only file for it after your insurance company paid on any medical claim you may have. However, you may choose to file to be reimbursed for any out of pocket expenses that you incurred.

If you have the insurance and are injured at an official Markland event, you must first pay all of your medical bills and then you can file for repayment from the insurance company. Our insurance DOES NOT directly pay any claim. However, you will be reimbursed within 8 weeks by the insurance company.

### Voting

This is your opportunity to have a say in the workings of Markland. Each official chapter sends two representatives to the semi-annual council meetings, held in the Spring and Fall. Every paid Markland Member has a vote at the Summer and Winter Althyngs, our semi-annual corporate meetings. If you cannot attend, you may send a proxy. Every vote counts.

## Introduction to Hierarchy

### Positions Within Markland

- ❖ Witan (Elected Positions at Summer Althyng)
  - Aeldorman, the President  
markland.aeldorman@gmail.com
    - The only position that can speak on behalf of Markland.
  - Shire-Reeve, the Head of Fighting
    - Head Reeve of the entire organization, works with the Steel Guild, Fencing Guild and Frat Fighters.
  - Bocman, the Secretary
    - The Plague Editor and the Webmaster work under the Bocman, but in practice the three positions work in conjunction with one another.
  - Bailiff, the Treasurer
    - Handles all transactions concerning Markland and maintains membership information.
- ❖ Plague/Pox Editor (Appointed Position)
  - The Editor compiles, edits, and mails the Pox and Plague. These documents are vital to running Markland.
- ❖ Webmaster (Appointed Position)
  - Provides updates and changes to [www.markland.org](http://www.markland.org) with all the latest information about us.
- ❖ Fyrd or Folk: This means you, the members of Markland! All paid Markland members are members of the voting body of the organization.

## Types of Events

### Althyngs

Vote! All paid members are given a vote at the Summer and Winter Althyngs. This is your opportunity to become involved in the policies and practices of Markland. What Markland does and becomes depends solely upon its members.

### Council Meetings

Council is a governing body of Markland that consists of two representatives from each official Markland chapter. The council meets at least twice a year, at least once between each Althyng and requires a Quorum, at least 50 percent group attendance, to be reached for any business decided there to be official. Any member can attend and contribute ideas or opinions but you must be a representative of a group to vote.

## Wars and Frat Events

Many households/groups of Markland host wars, whether it is for the Crown or for the pleasure of fighting. These are generally weekend camping events and may include public demos, but the principle activity is fighting. Vendors, feasts, and other activities will depend upon the host of the war.

### Feasts

Some Markland Groups/Households run feasts both closed and open to the public. Ticket prices vary dramatically from feast to feast. It is always a good idea to buy your tickets well in advance (and for a discount!). Bring your own tablecloths, plates, knives, goblets and garb. The hosting household provides food and entertainment. Details of official events will be listed in the Plague/Pox. Pay attention to the specifics of the event regarding alcohol and flame. Refer to the code words on page 4 for further interpretation.

### Arts and Sciences

Workshops, Craft Days, and the Frithstow are gatherings of members for the purpose of sewing garb, creating accessories, armor/weapon making, and sharing information.

### Fighter Practices

Most households/groups run their own fighter practices. Consult group contact for dates and times of private practices. If there are any regularly scheduled practices, they are listed in Plague/Pox on the same page as the schedule. There may be some in your area. It is always best to call and confirm the practice before you head out.

### Historical Encampments/Living History

Living History camps affiliated with Markland have won many awards for the presentations of military life throughout history. The encampments are required to be historically accurate in all details, including food preservation, weapons, tactical skills, clothing, crafts and activities.

### Rec Events

Battles are events at which Live Steel demonstrations occur. These events are usually of a higher caliber of authenticity than Frat Wars. Garb standards are often at this type of event.

## Markland Code Words

### Alcoholic Beverages

The legal drinking age in the states in which Markland operates is 21. Underage drinking is not allowed. Be respectful of your hosts and dispose of your containers properly.

### Alcohol at Events

- ❖ Sahara/Dry
  - Absolutely no alcohol of any kind in any container under any circumstances is allowed. This classification can be seen at some feasts and public demonstrations.
- ❖ Discretely Damp/Damp
  - If possible, bring alcohol to the site not in their original containers. If not, bring the containers with you and do not leave any alcohol on site.
- ❖ Wet
  - No restrictions whatsoever on alcohol.

### Feasts

- ❖ Provided
  - All food items are provided, and unless specified, plastic feast gear for you to use. All you need to do to enjoy the fun is show up and pay for tickets.
- ❖ Semi-provided
  - The hosts will provide several listed food items. Bring any additional items of food that you would like.
- ❖ Flame
  - Flame pertains to candles, not to smoking. You must ask your host for the location of the smoking area.
- ❖ No Flame
  - This means that candles and incense, no matter how they are contained, may not be lit at events. If you chose, you may still use them unlit for decoration.
- ❖ Enclosed Flame
  - Any flame that is enclosed in such a way that if it was knocked over, it would not cause the table cloth or other objects around it to catch fire. This pertains to incense and to candles.
- ❖ Any flame or Open Flame
  - If no mention is made of flame, then you can assume that open candles and incense are permitted.

## Event Ratings

- ❖ Official
  - This means that the host group has submitted an event form requesting an insurance binder from the Witan so that insurance will apply to the event. Markland fighting rules will be enforced.
- ❖ Unofficial
  - No event form has been filed. The Markland insurance binder does not cover unofficial events.

## Markland Fighting

Fighting falls into three classifications. Each class has its own set of rules. Check the website for documents about rules and explanations of how to make gear. We hold many Frat fighting events throughout the year. Rec/Steel fighting and Fencing happens rarely, but hopefully on the rise.

- ❖ Frat
  - Fratricidal fighting is a full contact sport using padded weapons and armor suitable for any real warrior. Combatants are attempting to make real contact with their opponents. The blows are sufficient for combatants to acknowledge verbally or putting your hand above your head when a killing blow has been received. Fratricidal fighting (or Frat fighting for short) has been around for quite a while.
  - There are many different types of fighters from archers and pike men to swordsmen and spearmen. There are two groups, light and heavy. An important rule: DO NOT HIT THE LIGHTS. You may tap them or tell them that they are dead. They are the ones in international orange.
- ❖ Recreational or Steel
  - Recreational fighting is choreographed fighting, fought with real steel and armor. New fighters are trained with wooden weapons before being tested and qualified to use steel. You must be certified to fight Rec and further certification allows you to become a Steel Qualifier.
- ❖ Period Fencing
  - Period fencing is not choreographed and is fought using the known period styles and weapons of the early Renaissance.

## Current Official Groups/Households

Markland has several 'official' groups and households, as well as many individuals who are not affiliated with any particular group. Each group has their own membership requirements – as well as their own rules, interests and personalities - and it varies vastly from group to group. You do not need to belong to a group or household to be involved in Markland – in fact, many people choose not to be affiliated with a household at all.

- ❖ Clan Clonakility (NJ/E. PA); Dominic Gullo; mignignack@gmail.com
- ❖ Companions of the Cross (S. NJ); Joan Karasinski; jkarasinski80@gmail.com
- ❖ Head Clan (DE/MD); Eric Dennis
- ❖ House Black Moon (E. PA); David Lindsey; gunther18964@yahoo.com
- ❖ House Blackrill (C. NJ); Ilea Santiago; House.Blackrill@gmail.com
- ❖ House Von Draken (E. PA); John Smith; dukekyrin@comcast.net
- ❖ The Ladies Order of the Claddagh; Crystal Perry; Crystallperry79@gmail.com
- ❖ Longship Company (S. MD); Bruce Blackistone; asylum@earthlink.net
- ❖ Maryland Medieval Mercenary Militia (MD; Justin Briley; skurfiska@gmail.com
- ❖ Order of the Lost Boys (MD/DE/PA/NJ); David Perry; lostboytl@aol.com
- ❖ Pirates of the Lost Cause (E. PA); Deb Hartmann-Healy; dhartart@aol.com
- ❖ Rhineguard (C. NJ); Christopher Andrews; kelsrik1976@aol.com
- ❖ Rivenwood (S./C. NJ) - Todd Minetti; tminetti@gmail.com
- ❖ Scarlet Cross (Rutgers University); Kenneth Maneely, Jr.; rutgersscarletcross@gmail.com

## Current Guilds

Unlike groups and households, guilds are open to anyone who wishes to join and most have no membership requirements other than a desire to be more involved. You don't even have to be a paid member of Markland to be part of a guild. Many Marklanders are members of more than one guild, and guilds are not determined by group affiliation.

- ❖ A&S Guild; Lisen Minetti; lisenm023@gmail.com
- ❖ Archery Guild; Jill Cloud; jillian\_cloud@yahoo.com  
John Blevins; jblevi320@gmail.com
- ❖ Bardic Guild; Justin Briley; skurfiska@gmail.com
- ❖ Children's Guild; Laura Swoboda; Laura\_Swoboda@yahoo.com
- ❖ Feast Guild; Jill Cloud; jillian\_cloud@yahoo.com
- ❖ Reeve's Guild; Justin Briley; skurfiska@gmail.com
- ❖ Siege Weapons Guild; Christopher Andrews; kelsrik1976@aol.com
- ❖ Thrown Weapons Guild; David Lindsey; gunther18964@yahoo.com

## Garb

Garb is what we call the clothing we wear to events. We avoid the word "costume" because we are not dressing up for Halloween. We are putting on clothing that represents the historical clothing worn by people in the period that we re-enact.

With this in mind, a few points must be made. Markland is a historical organization dedicated to educating us and the public about medieval history. As such, fantasy, Goth, Renn and modern clothing are not acceptable at any Markland event after arrival (barring those at which garb is not required). Elf ears, vampire fangs, broomstick skirts, chain mail bikinis, or bondage wear is inappropriate and will be treated as such. Live Action Role-Playing Games are fun, but we are an historical organization. Leave the fantasy costumes at home.

### Basic Markland Garb:

While garb varies greatly over geographic area and time period, only the most basic attempt at garb is needed. For men, this could be plain pajama pants, a basic t-shirt, belt, boots, and a tabard. For a tabard you just need a rectangle of fabric and cut a hole in the middle for your head. For women it could be a long dress or skirt, blouse, sandals, and a tabard. You will find patterns on page 6 for a more authentic tunic and gown. If you do not have garb, many people have some they can lend out. Don't be afraid to ask. Just try to avoid sneakers, neon colors, cheap costumes, and modern materials like plastic.

### Garb Levels at Events:

- ❖ None/Not Specified
  - Medieval garb is optional.
- ❖ Show
  - You will be dressing for the public. Try to be as period as possible but some concessions can be made. On the Frat field, you are not expected to be wearing nice garb.
  - Wool or linen trousers and sturdy shoes would be advised. Many event organizers go by the 10 ft rule and allow plausible modern clothes rather than garb.
  - Keep in mind that the public may be looking at you. They may have incorrect preconceived notions, but we are historical re-enactors.
- ❖ Authentic
  - This means that all of the details count. Footwear, eyewear, cooking utensils, thread...etc. No detail is too small to be ignored.

## Tunics

The tunic is the basic men's garment, and it was common to wear a will one over a linen undertunic. Your tunic should reach at least to your knees, and the skirt is flared with gores. The sleeves should fit fairly closely along the forearms and can end anywhere between wrist and fingertips.

The pattern is designed for 2 yards of 45"-wide fabric: 1 1/3 yards for the body, and 24 inches for the sleeves. Wrist measurement (narrow end of "S") equals the distance around your closed fist plus an inch for seam allowance. If your fabric is wider than 45 inches (most wool is), you can widen the body halves, but leave the sleeves 22 inches wide at the top unless you really need the space. The leftover fabric can become more gores, if needed.

To assemble, sew the body halves together only at the top, and cut the neck hole out as small as possible – round, semi-circular, or square, with a short slit. Sew the 2 little gore halves (G) together to match the shape of the big gore; sew the gores to either side of the back panel, or in slits at the center front and back. (It is even better to have gores in the center and at the sides.) You will probably need to trim the sleeves to fit closer along the forearm, but not too tight. Sew the sleeves to the body, centered on the shoulder seam. Finally, fold the whole thing in half (into a tunic shape), and sew each side from wrist to armpit to hem.

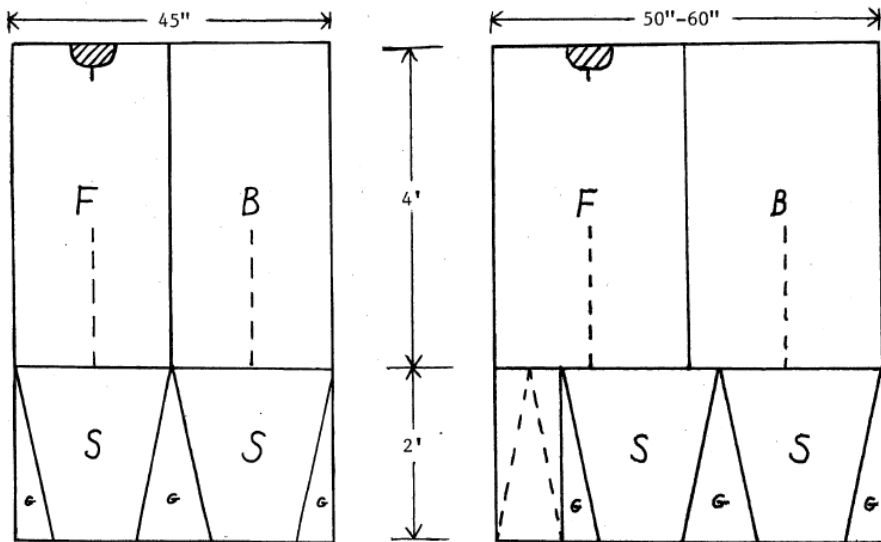

## Gown

The gown is just a full-length tunic for women. The front and back gores reach to the waist, but the side gores may reach to the armpits. The sleeves are made to fit the forearms, but the body is not shaped – there are no darts, gathers, or curved seams. Certainly, the hem is not slit!

As with men's closing, it was common to wear a wool dress over a linen underdress (shift or chemise), but women's fashions had a little more variation through time. Tenth and eleventh century Norse and Saxon dresses tended to be a looser fit, bloused over the belt, and sometimes an extra overdress was worn, knee-length with shorter or unfitted sleeves.

Norman styles were closer fit, so side gores should only come to the waist. In the twelfth century, the overdress could be loose, or laced up the back or the sides to give a snug fit in the torso; flared sleeves were common in the upper class. In the thirteenth century, everyone was back to a loose fit with tight sleeves.



front and back can be one piece or have slightly sloped shoulders.

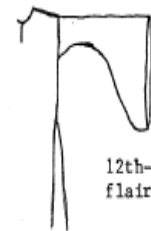

12th-century flared sleeve

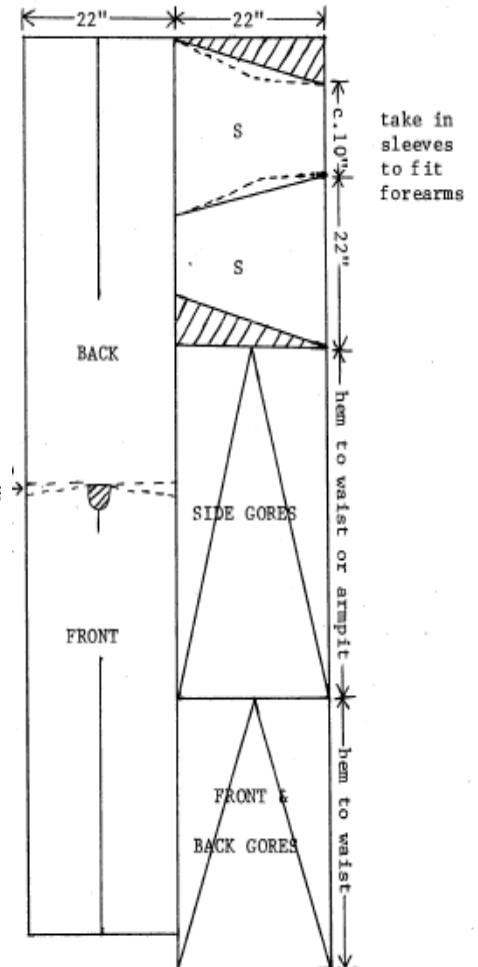

## Camping Gear

Suggested gear and supplies to bring while camping in Markland. Some of these items you will be able to share, or purchase at a convenience store nearby if needed. **\*\*This is not an exhaustive list\*\***

### Individuals

- ❖ Nylon Tent and Rain Fly (including tent stakes and mallet)
- ❖ Tarp (to place underneath)
- ❖ Sleeping bag (Preferably a cot, or a layer under the bag)
- ❖ Blankets and Pillows
- ❖ Garb and Accessories
- ❖ Extra Clothes (socks, shoes, underwear)
- ❖ Camp Chair
- ❖ Lantern / Lighting / Flashlights
- ❖ Food and Drink (Also snacks and lots of water)
- ❖ Extra Toilet Paper
- ❖ Trash Bags
- ❖ Sunscreen and Bug Spray
- ❖ Extra Batteries
- ❖ Rugs / Flooring (very important for Canvas Tents)

### Larger Groups

- ❖ Shade Tent
- ❖ Table
- ❖ Kitchen: Stove & Propane / Cast Iron / Dishes
- ❖ Firestarter / Lighter
- ❖ Tiki Torches & Fluid
- ❖ Fire Extinguisher
- ❖ First Aid Kit
- ❖ Fire Poker & Axe

### Notes:

- ❖ Some sites have limitations on outside firewood and campfires. Please check with the group running the event for limitations!!
- ❖ It rains. A lot. When pitching a tent, take into consideration where you're setting up to make sure you aren't in a ditch or divot that could retain pools of water.
- ❖ Layer, layer & layer! It may be a balmy 75 degrees during the day, then drop to 40 degrees at night. Or it might (will) rain. The forecast could be completely off. Bring layers. Lots of them. And extra socks. Maybe a hat.
- ❖ For late fall events, you will need more than one sleeping bag.

## Feast Gear

At some feasts (at Wars and at Feast day events) plastic cutlery and plates will be available. However, a set is easy to put together, a great way to reflect your own style, and really adds to the experience!

### Feast Set:

- ❖ Plate
- ❖ Bowl
- ❖ Mug or Goblet
- ❖ Knife, Fork, Spoon
- ❖ Bottle Opener / Wine Key
- ❖ Cloth Napkin (Table Cloth for groups)
- ❖ Pitcher (For Groups)
- ❖ Cutting Board & Cutting Knife (For Groups)
- ❖ Candles/Candle Holders (If open flame is permitted)
- ❖ Lighter (If open flame is permitted)

### Notes:

- ❖ Recommend to use wood or metal for your feast set.
- ❖ If you have allergies, please check with event hosts for ingredients!
- ❖ Open flame (candles) is not permitted at all events. Please check with event hosts (see section on Code Words for guidance).
- ❖ Rules governing alcohol consumption vary from feast to feast. Please check with event hosts (see section on Code Words for guidance).
- ❖ If tickets for feasts are available in advance, consider purchasing them. They are usually discounted and allow the hosting group to better plan.

## List of Individual Specialties

One of the most difficult things about getting started in Markland is knowing where to turn for information. With that in mind, we have compiled a list for you! So many of us know a little bit about everything, or a lot about a few things. Some of us have been honing our craft for decades, others have a passion for knowledge that has been driving us to learn our craft in recent times. But all are willing to share their information, experience, mistakes and resources with anyone willing to learn.

The list on the following pages includes a sampling of what we are able to teach, and those who are willing to teach, along with their contact information. The information is subject to change from time to time.

## Individual Specialties

Kolfinna Jodísardottír (Jill Schaffling)

Schafflingja@gmail.com

- Drop spinning
- Nálbinding
- Inkle weaving
- Basic garb sewing
- Cheese making

Brigid the Fervent (Jill Cloud)

Jill\_Cloud@yahoo.com

- Arrow construction
- Light archery
- Camp cooking

Brenna Brynwyf (Megan Gallagher)

megangallagherking@gmail.com

- Sewing
- Vikings
- Clothing
- Persona

Edwyn le Clerc (Dan Adler)

edwynleclerc@gmail.com

- Greek mythology
- Norse mythology
- Genealogy
- Heraldry
- 12/13 century England & Wales
- Medieval church

Lothar (Sean Lowman)

eyerunmayden@gmail.com

- Sewing
- Handsewing
- Dark Age Clothing
- Buttonholes
- Eyelets

Captain Faris Rafi al-Qasid (Sean Vannoy)

flounderolb@gmail.com

- Frat Fighting
- Armor construction
- Sewing Garb
- Weapon construction
- Mead making
- Leatherworking
- Embroidery
- Feast preparation

Wilhelm Greycloake (William Marlow)

Willing to teach whatever he knows – one of the first members of Markland, his knowledge covers a wide topic of information

Sir Gareth Wolvesblood (John Blevins)

Jblevi320@gmail.com; 732-996-9143

- Archery
- Leatherworking
- Sewing
- Armor making

Sir Kenneth of Brunswick (Todd Minetti)

tminetti@gmail.com

- Frat Fighting (Sword/Shield & Spear)
- Weapon Construction
- Battle Tactics
- Event Organization